

PW6-110 – 12V HIGH EFFICIENCY PHOTOVOLTAIC MODULE With Universal Junction Box

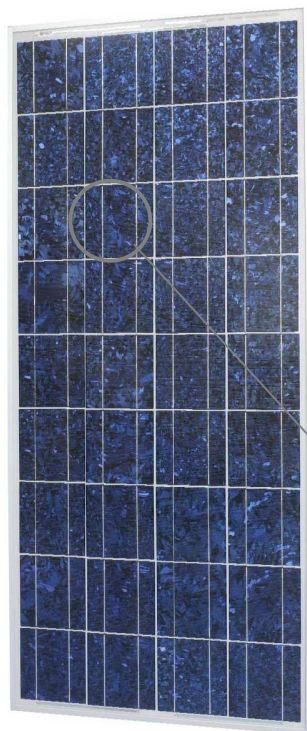

- Grid connected large scale system
- Power plants
- Buildings integration
- Water Pumping
- Telecommunications
- Rural electrification

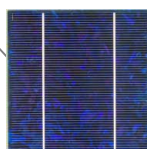

The PW6-110 is made of 4 X 9 high efficiency (up to 15%) 6 inch polycrystalline solar cells (150 mm X 150 mm), with a silicon nitride anti-reflective coating.

The PW6-110 is Photowatt's new born high efficiency module. Easy to handle, this module delivers a maximum power with an optimal size.

The PW6-110 module uses Photowatt's multicrystalline technology. The solar cells are individually characterized and electronically matched prior to interconnection. Encapsulation beneath high transmission tempered glass is accomplished using an advanced, UV resistant thermal setting plastic. The encapsulant, ethylene vinyl acetate, cushions the solar cells within the laminate and protect the cells from etching. The rear surface of the module is completely sealed from moisture and mechanical damage by a continuous high strength polymer sheet.

The PW6-110 is using a reinforced transparent anodised aluminium frame, designed to meet Photowatt's High Quality Standards for corrosion resistance (lifetime tested 3 times longer than requested by CEI 61215).

With a tolerance improvement to +/- 3%, the PW6-110 module ensures more power homogeneity in installations, and a financial investment corresponding to the real power produced.

POWER TOLERANCE : +/- 3%

EFFICIENCY WARRANTY : 25 YEARS*

PRODUCT WARRANTY : 5 YEARS*

PW6-110		12 V Configuration	
Typical power	W	110	
Minimum power	W	106	
Voltage at typical power	V	17,2	
Current at typical power	A	6,4	
Short circuit current	A	6,9	
Open circuit voltage	V	21,7	
Maximum system voltage	V	770V DC	
Temperature coefficient	$\alpha = +2,085 \text{ mV}/^\circ\text{C}$; $\beta = -79 \text{ mV}/^\circ\text{C}$; $\gamma \text{ P/P} = -0,43 \% / ^\circ\text{C}$		
Power specifications at 1000 W/m ² : 25 °C : AM 1,5			



*According to general warranty conditions
Datas subject to evolutions – Last update : September 2003

Module dimensions

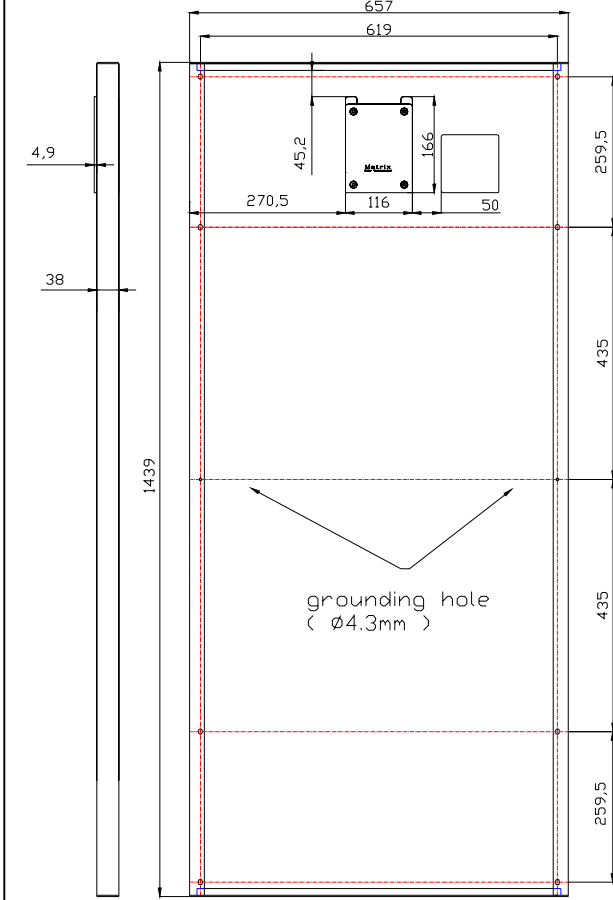

- ➔ Module weight: 13 Kg
- ➔ Module Size :
1439 mm x 657 mm x 45 mm
- ➔ Packaging per 2 units :
1563 mm x 689 mm x 102 mm, 28 Kg
- ➔ Maximum pallet size (34 modules)
1600 mm x 700 mm x 1770 mm, 491 Kg



The universal junction box accepts cables as large as 1,5 mm² to 4 mm² (AWG11 to AWG16)

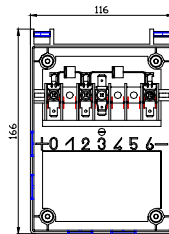

The module is protected by 2 schottky diodes (1 by-pass diode for 18 cells)

Frame

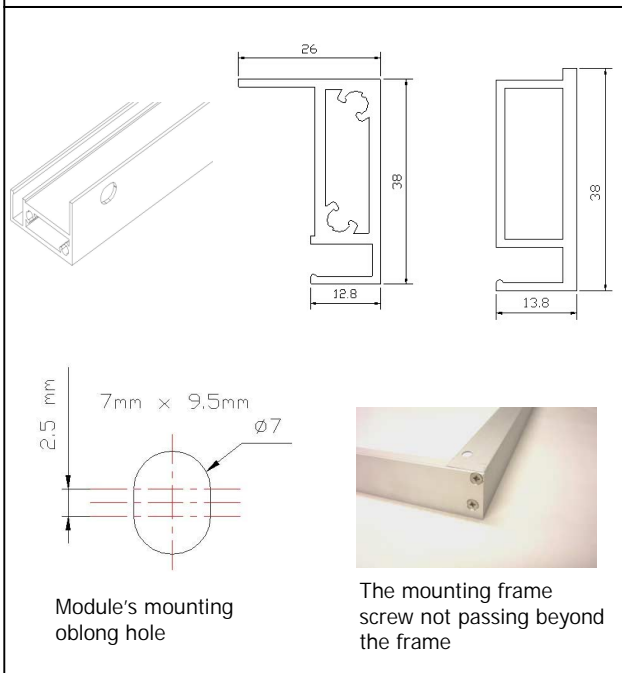

PW6-110 Characteristics

Ptyp : 110 Watts (12V)

